

49-LOCK NUT.6
51-WASH.1-6-10
38-BOLT.6.90!

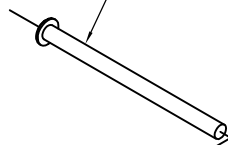

31-R.AL.6-70

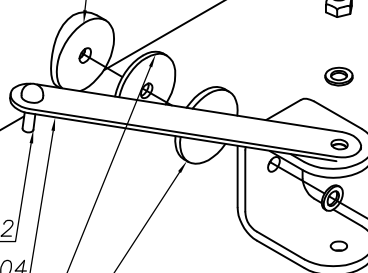

5-SKR.57.6

33-RIVET_AL.4-12

22-SKR.104
29-SKR.455.03
30-SKR.455.04

53-W.FL.1-6-24

18-SKR.93

45-BOLT.6.62
49-LOCK NUT.6
51-WASH.1-6-10

4-SKR.37.2

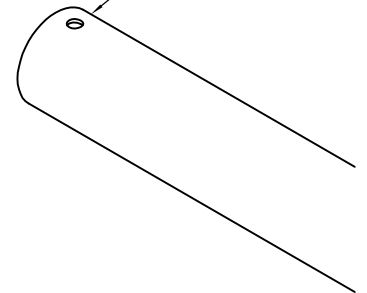

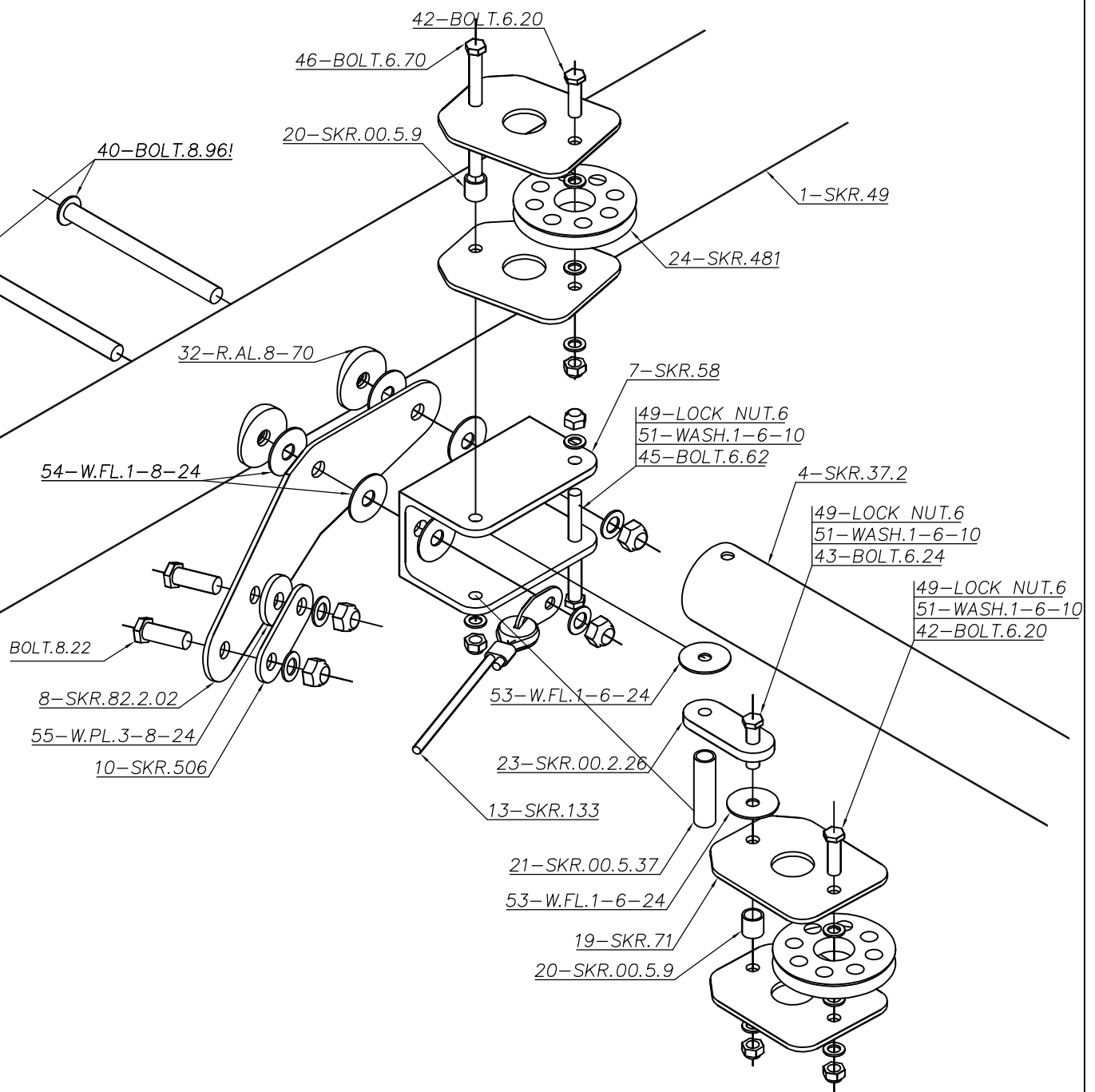
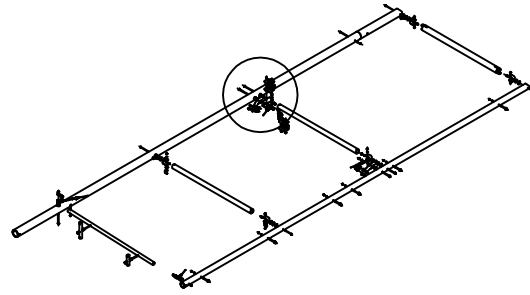

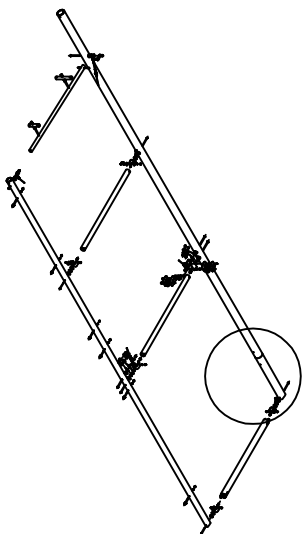

38-BOLT.6.90!
51-WASH.1-6-10
49-LOCK NUT.6

1-SKR.49_SHORT

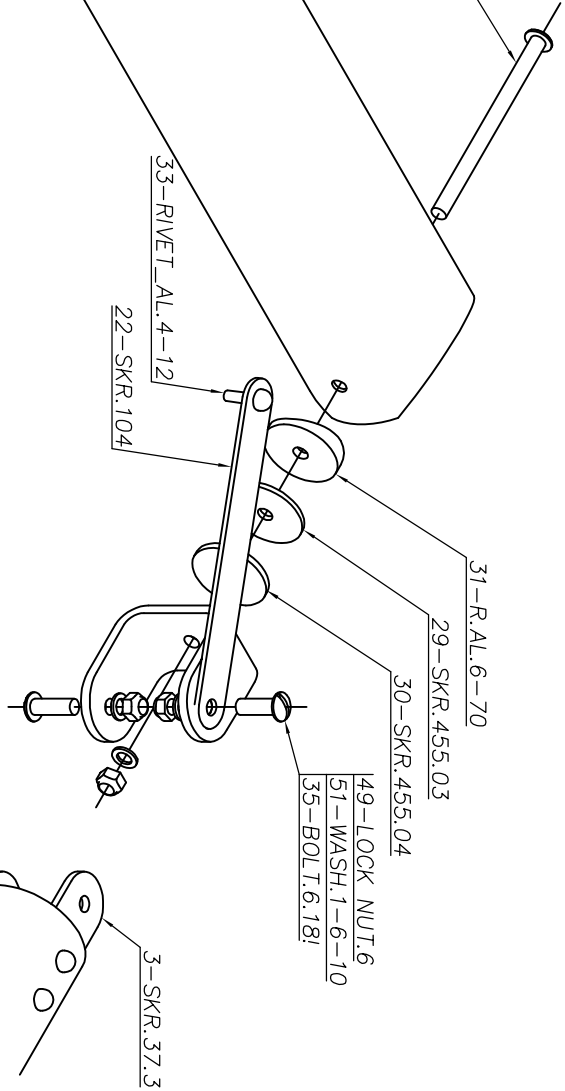

33-RIVET_AL.4-12
22-SKR.104

31-R.AL.6-70
29-SKR.455.03
30-SKR.455.04

49-LOCK NUT.6
51-WASH.1-6-10
35-BOLT.6.18!

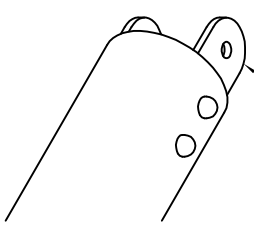

3-SKR.37.3

SKR. TK.27/4_Short

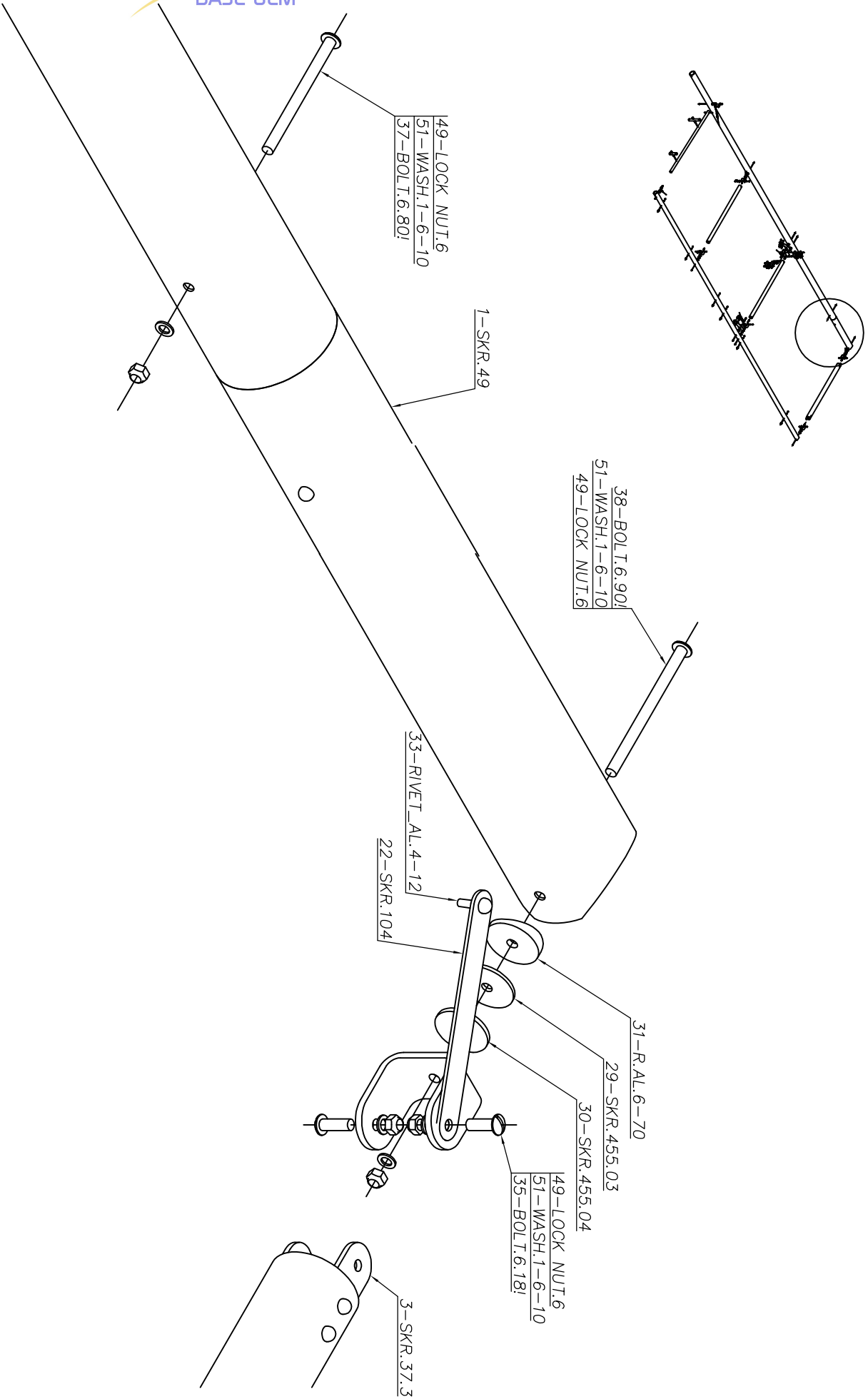

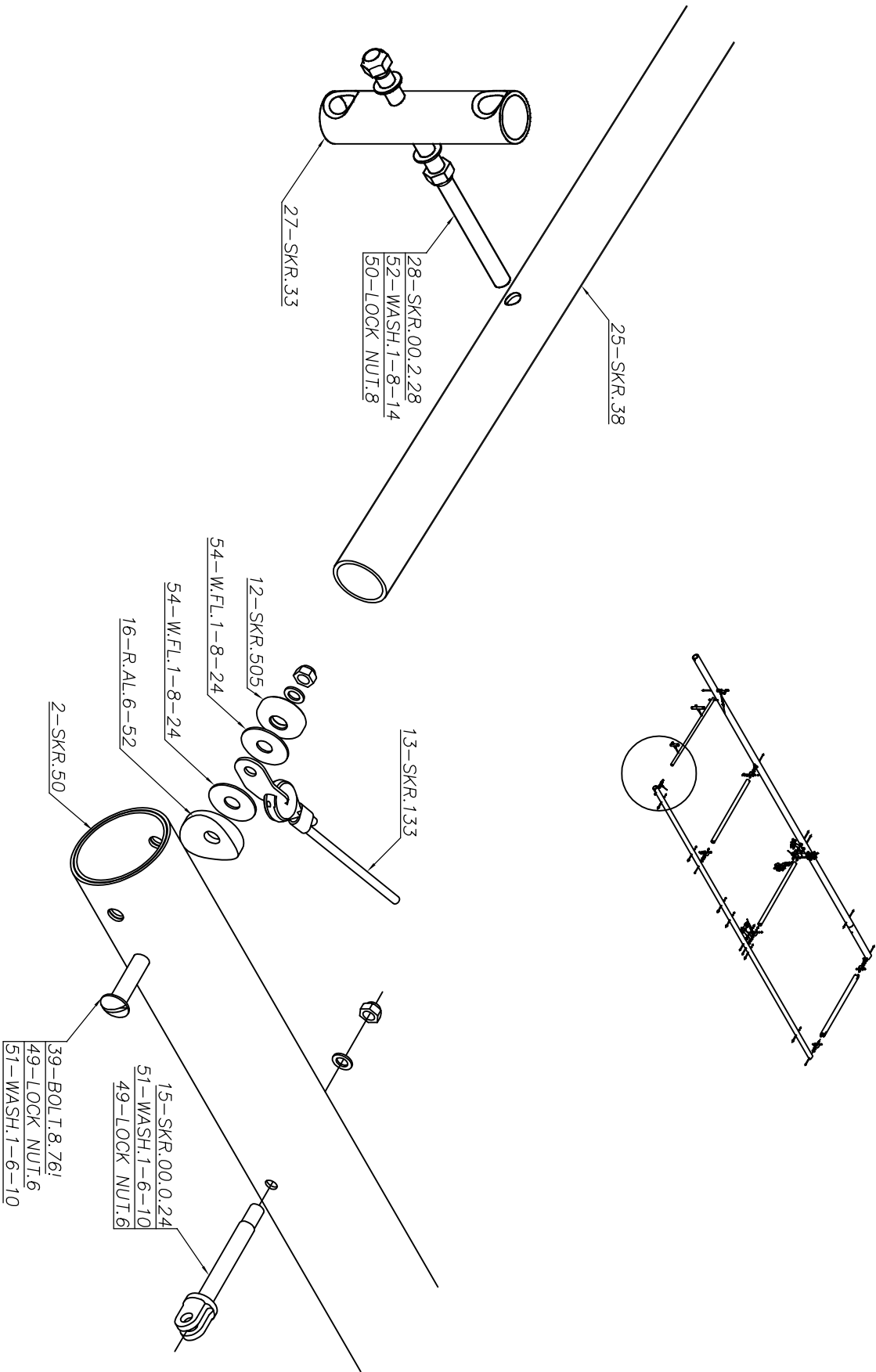

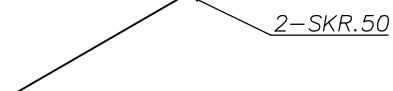
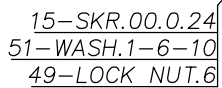
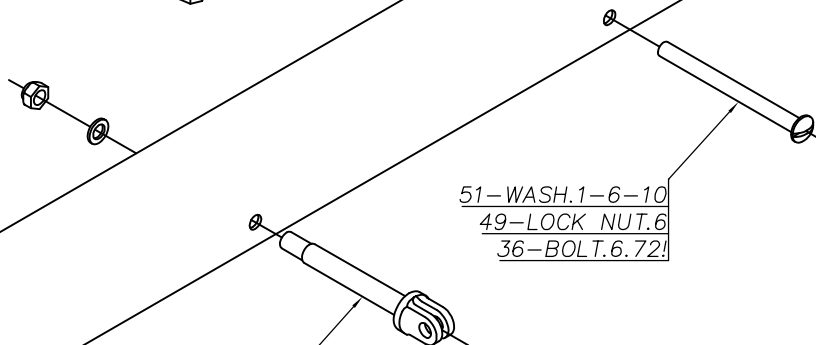
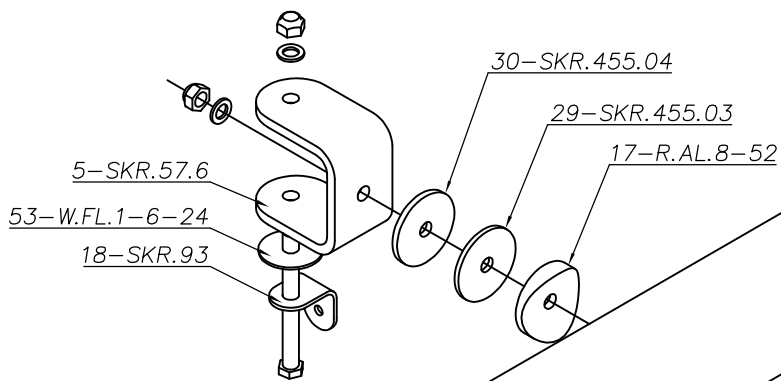
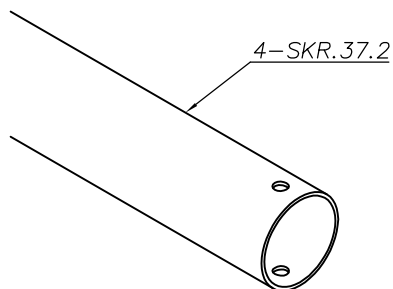
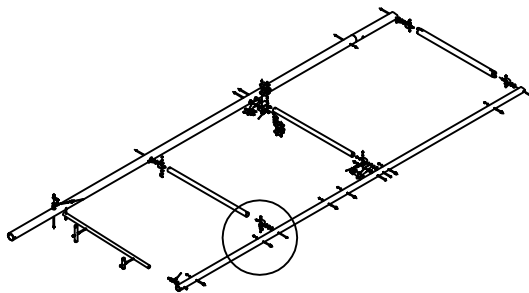

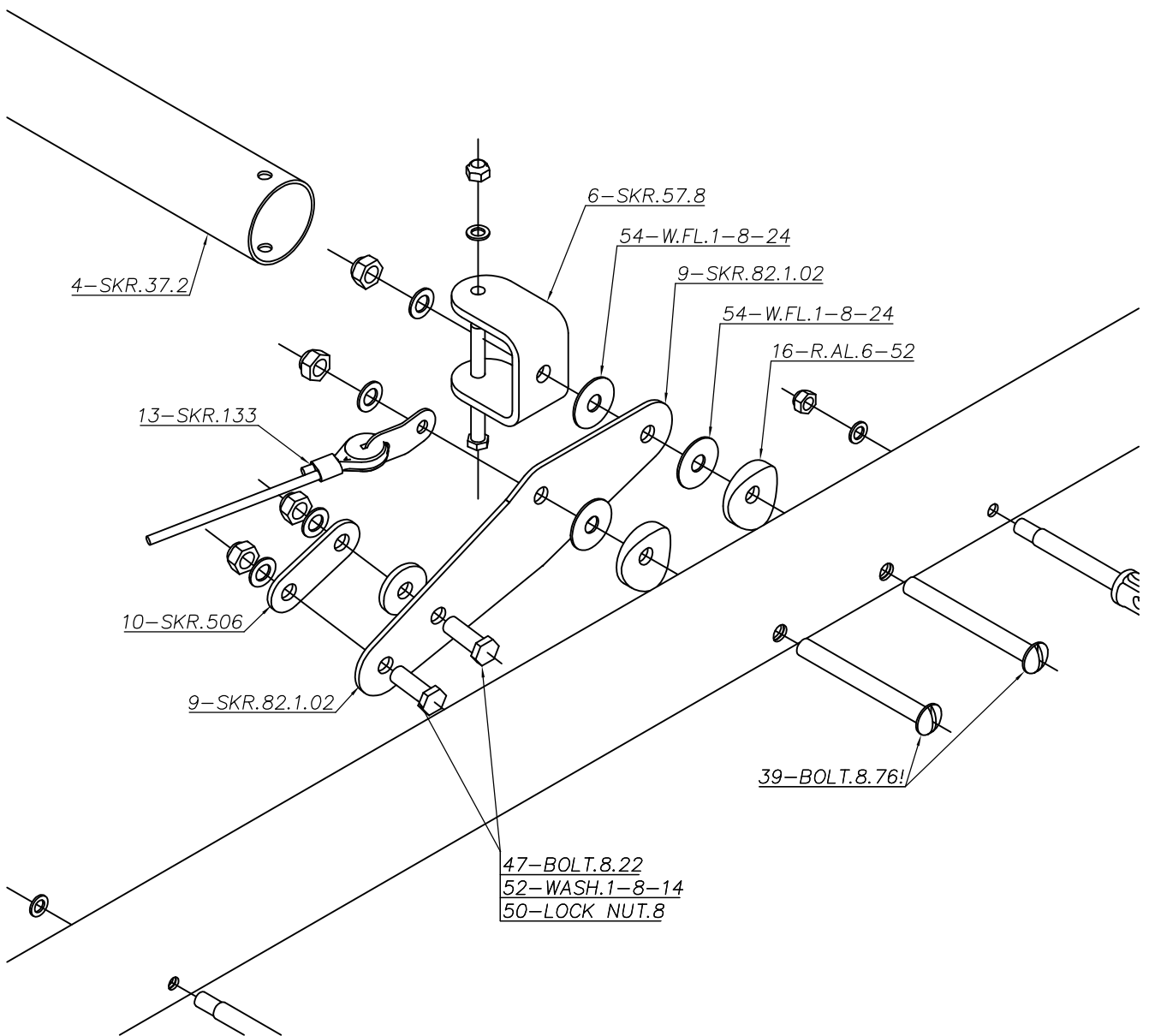
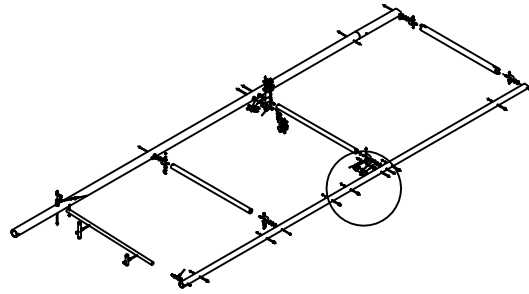

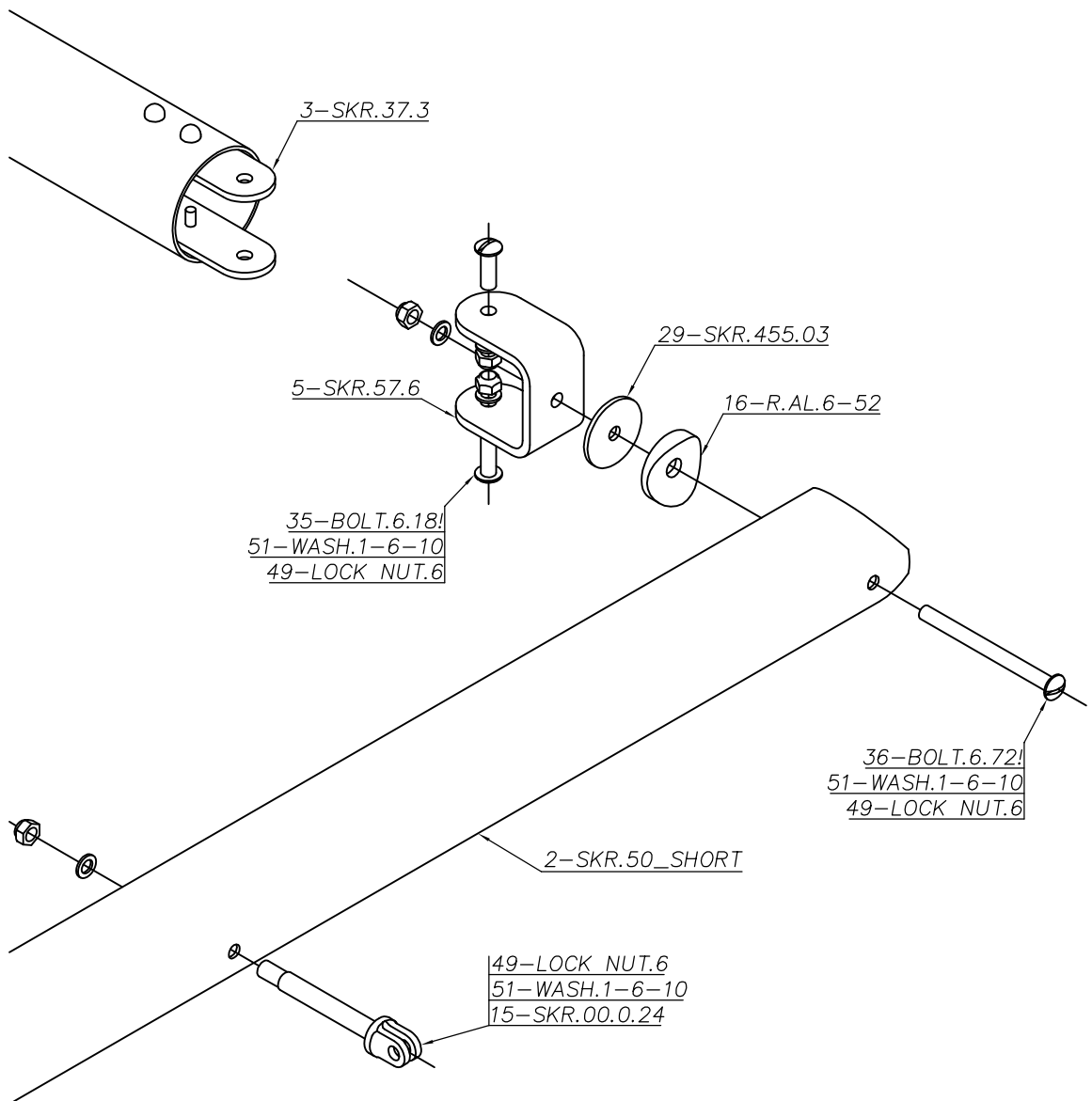
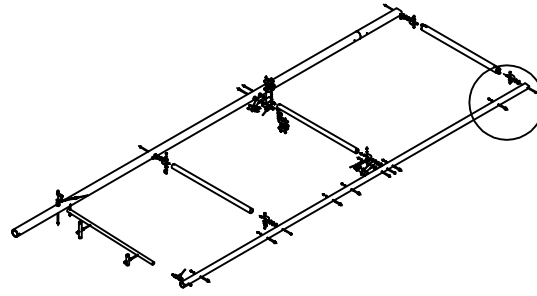

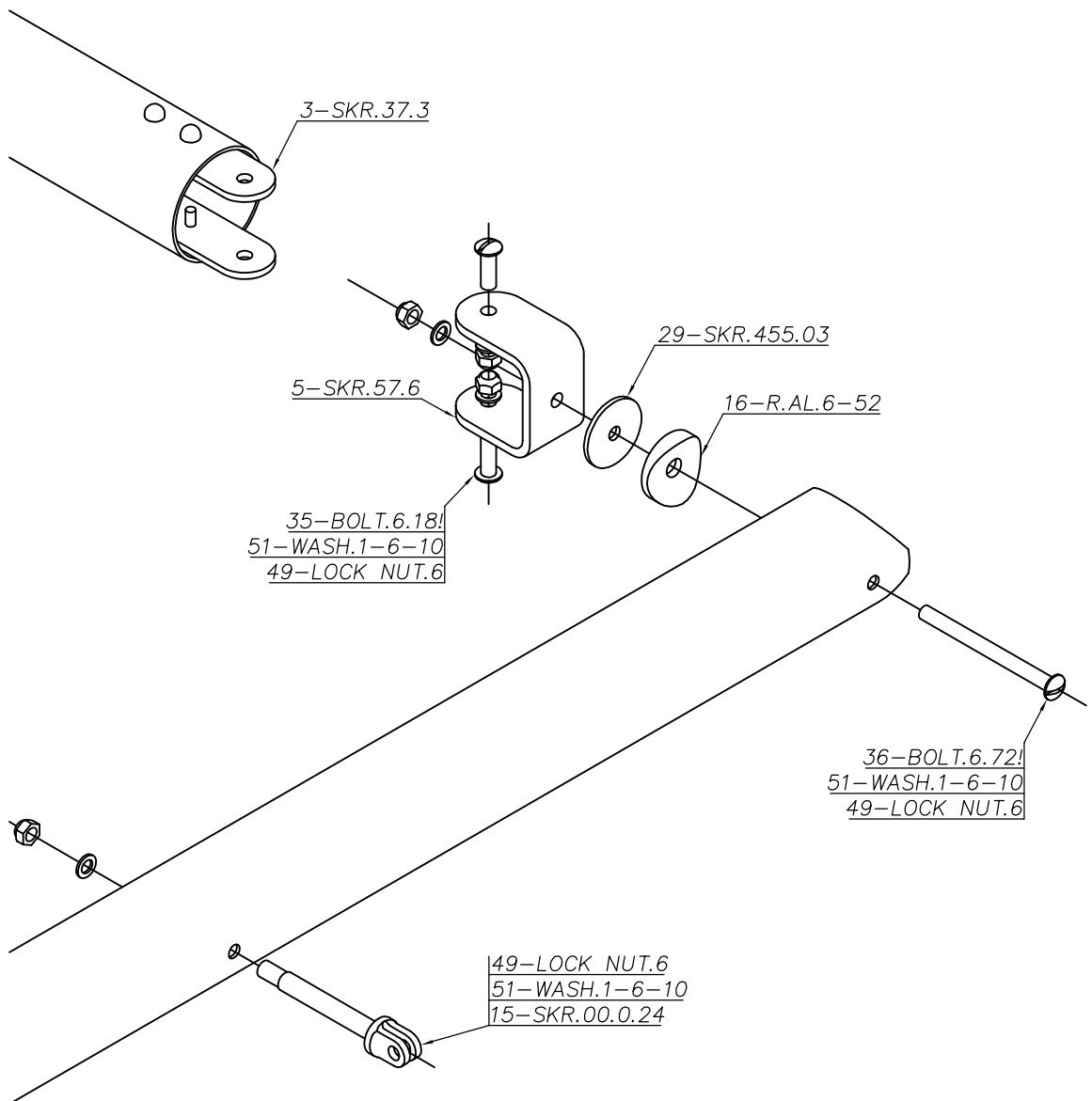
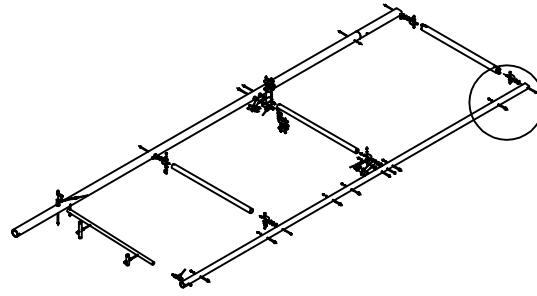

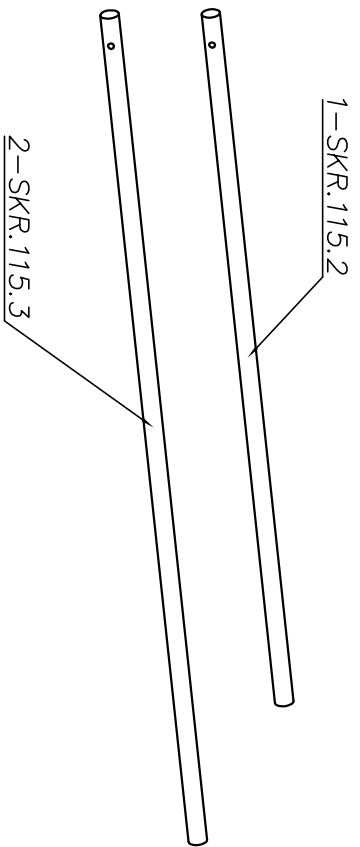

SKR. TK.28

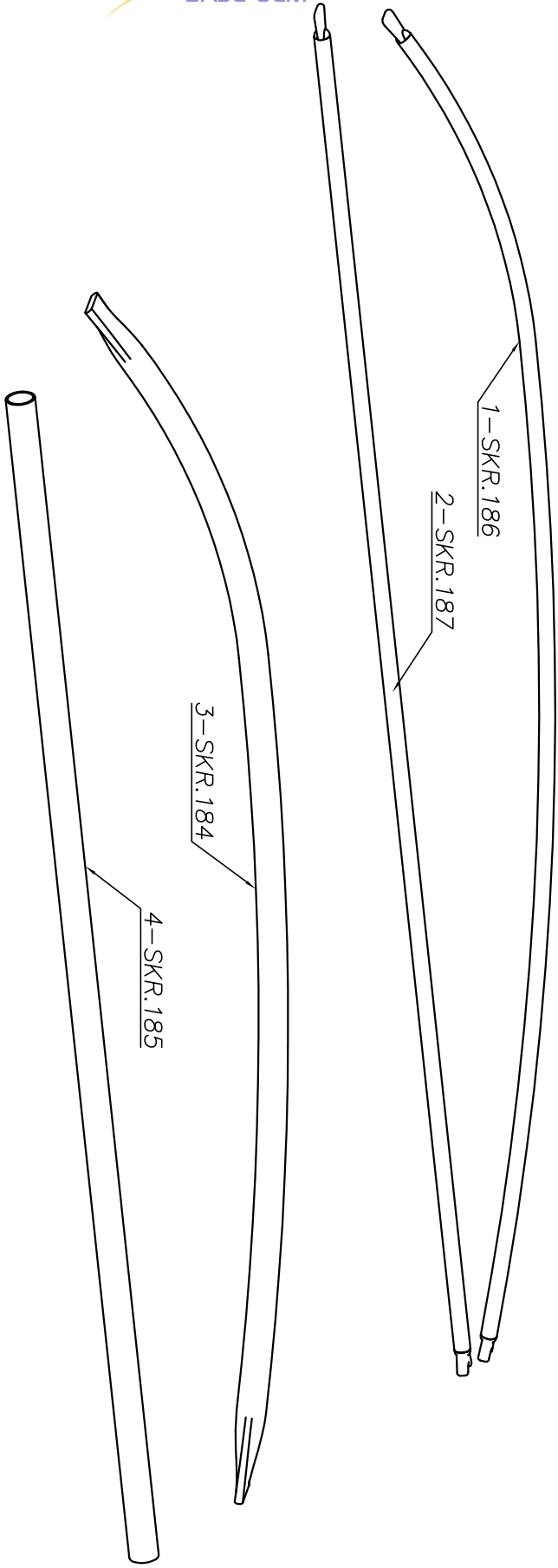

SKR. TK.29